



HSM (High-speed Scanning Module) User's Manual



References found in this document to prior company and division names such as General Scanning Inc., GSI Lumonics, and GMAX now refer to General Scanning Optical Scanners, a member of GSI Group Inc.



© December 2006, GSI Group Inc.

GSI Group and General Scanning
are registered trademarks.

P/N: 7OM-1020
Revision H

The information contained in this document is the sole property of General Scanning.
The disclosure of this information does not constitute the release of any proprietary rights therein.
Permission to reproduce this information or the products disclosed herein must be obtained in writing from General Scanning.

www.gs-scanners.com

Contact Information

Americas

39 Manning Road
Billerica, MA 01821
U.S.A.
TEL: +1 (978) 439-5511
FAX: +1 (978) 663-0131
E-mail:
ScannerSales-Americas@gSIG.com
Toll Free: +1 (800) 342-3757

Europe

Einsteinstrasse 2
D-85716 Unterschleissheim
Germany
TEL: +49 (89) 31707-0
FAX: +49 (89) 31707-250
E-mail:
ScannerSales-Europe@gSIG.com

Asia

Technoport Kamata, 16-1
Minami-Kamata 2-Chome,
Ohta-Ku Tokyo 144-0035, Japan
TEL: +81 (3) 5425-7733 [Sales]
+81 (3) 5714-0557 [Service]
FAX: +81 (3) 5425-7738 [Sales]
+81 (3) 5714-0566 [Service]
E-mail:
ScannerSales-Asia@gSIG.com

Table of Contents

1	IMPORTANT INFORMATION	4
1.1	ESD WARNING	4
1.2	WARRANTY INFORMATION	4
1.3	CUSTOMER SUPPORT	5
1.4	UNPACKING	5
2	INTRODUCTION	6
2.1	THEORY OF OPERATION	6
2.2	SCAN HEAD SPECIFICATIONS – ALL CONFIGURATIONS	7
2.2.1	<i>YAG lens specifications:</i>	7
2.2.2	<i>CO2 lens specifications:</i>	8
2.3	POWER SUPPLY REQUIREMENTS	9
2.4	ENVIRONMENTAL REQUIREMENTS	9
2.5	MIRROR SPECIFICATIONS	9
3	SYSTEM DESCRIPTION	10
3.1	ANALOG INTERFACE	10
3.1.1	<i>Analog Pin-Out Description</i>	11
3.2	DIGITAL INTERFACE	12
3.2.1	<i>Digital Interface – Pin-Out</i>	13
4	INSTALLATION	14
4.1	MOUNTING HSM15M2 SCAN HEAD	14
4.2	INTERCONNECTIONS	15
5	SAFETY AND WARNINGS	16
5.1	LASER SHUTTER INSTALLATION	17
5.2	INSTALLATION SAFETY REQUIREMENTS	17
6	HANDLING / MAINTENANCE	19
6.1	MIRROR CLEANING	19
7	TROUBLESHOOTING	21
8	GLOSSARY	22
9	APPENDIX A: ADDITIONAL RESOURCES	23
10	APPENDIX B: OUTLINE DRAWINGS	24
10.1	HSM15M2 ANALOG OR DIGITAL INTERFACE SCAN HEAD	25

1 IMPORTANT INFORMATION

1.1 ESD WARNING



The OEM electronics that *General Scanning* manufactures - including galvanometers and servo controllers - are electrostatic discharge (ESD) sensitive. Improper handling could therefore damage these electronics. *General Scanning* has implemented procedures and precautions for handling these devices and we encourage our customers to do the same. Upon receiving your components, you should note that it is packaged in an ESD-protected container with the appropriate ESD warning labels. The equipment should remain sealed until the user is located at a proper static control station*.

Note: Any equipment returned to the factory must be shipped in anti-static packaging.

(*) A proper static control station **should** include:

1. A soft grounded conductive tabletop or grounded conductive mat on the tabletop.
2. A grounded wrist strap with the appropriate (1 Meg) series resistor connected to the tabletop mat and ground.
3. An adequate earth ground connection such as a water pipe or AC ground.
4. Conductive bags, trays, totes, racks or other containers used for storage.
5. Properly grounded power tools.
6. Personnel handling ESD items should wear ESD protective garments and ground straps.

1.2 Warranty Information

The Customer shall examine each shipment within 10 days of receipt and inform General Scanning of any shortage or damage. If no discrepancies are reported, General Scanning shall assume the shipment was delivered complete and defect free. General Scanning warrants products against defects up to 1 year from manufacture date, barring unauthorized modifications or misuse. Repaired product is warranted 90 days after the repair is made, or one year after manufacture date - whichever is longer.

Contact Customer Service to obtain a Return Materials Authorization number *before returning any product for repair*.

All orders are subject to the General Scanning Terms and Conditions and Limited Warranty. Visit our website for the latest version of these documents and other useful information.

IMPORTANT: Optical Scanners are normally tuned, serialized and warranted as a matched set for optimized performance. Mismatched components negatively affect performance and void the warranty. A matched set typically consists of galvanometer motor, mirror load, electronic driver board and interface cable.

Customers assume all responsibility for maintaining a laser-safe working environment. OEM customers must assume all responsibility for CDRH (Center for Devices and Radiological Health) certification.

1.3 Customer Support

General Scanning has support services to address your questions or concerns with either the product or manual you are using. Before calling for assistance, be sure to refer to any appropriate sections in the manual that may answer your questions. Call General Scanning's Customer Service Department Monday through Friday between 8 A.M. and 5 P.M. local time (GMT -05:00 Eastern Time (US & Canada)).

The customer service personnel will be able to give you direct assistance and answers to your questions.

1.4 Unpacking

The package you receive includes those items listed in the packing list.

1. **Carefully** unpack the contents from the box.
2. Save shipping container and packaging material in case you need to return unit for service.
3. Check contents of the box against the packing list to ensure all parts were received.
4. Inspect each item to ensure it was not damaged during shipment.

2 INTRODUCTION

GSI Lumonics presents the HSM15M2, our High Speed Module at 15mm clear aperture featuring M2 galvanometers and high bandwidth servo technology. This manual addresses the hardware installation, operation, and handling and refers you to other manuals for more information on software control. The HSM15M2 series consists of two control interface options: analog and digital configurations.

Be careful to observe the information in the Safety and Warnings section that alert you to the hazards and the laser beam path you can expect while running the HSM15M2. The HSM15M2 utilizes galvanometers and reflective mirrors that create a pyramidal zone of direct hazard, as well indirect hazards outside the main lasing zone. Please be alert to laser safety considerations and specific procedures regarding the HSM15M2 scan head and the laser you are using.

2.1 Theory of Operation

GSI Lumonics' 2-axis galvanometric Scan Heads provide the capability of deflecting optical beams in a XY plane for all possible laser applications. The synchronized actions of two galvanometer servo-controlled mirrors direct the laser beam to specific locations on a target in both the X and Y directions. The HSM15M2 Scan Head Module is a multi-purpose dual-axis beam steering unit. The Scan Head contains two M2 galvanometer scanners (X and Y), a servo driver board, and optional Lens Kit Assembly. The lens kit consists of a field flattening lens and a lens holder that mounts onto the Scan Head.

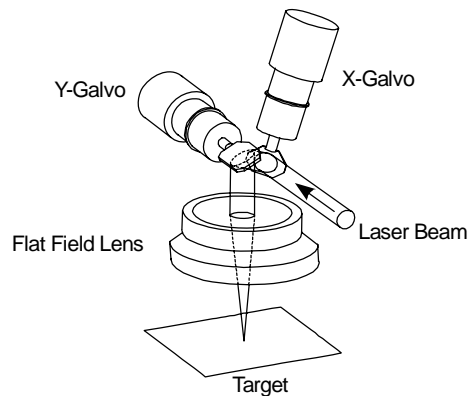

Figure 2.1: Simple beam path through the HSM15M2 Scan Head.

There are two types of electronic interfaces to the HSM15M2 Scan Head: Analog and Digital. The analog version requires a customer supplied analog signal to command the individual axes of the Scan Head.

The digital interface version contains an additional Digital to Analog Receiver (DAR) board that interfaces with a HC/3 card. The HC/3 is a PCI card that fits internal to a PC and can be used with GSIL software to easily control the HSM15M2 scan head as well as provide laser control. PC-MARK MT™ and WinMCL Plus™ are developer-level control software modules that work with the HC/3 card.

2.2 Scan Head Specifications – All Configurations

2.2.1 YAG lens specifications:

Laser Type	YAG	YAG	YAG	YAG
Wavelength λ (nm)	1064	1064	1064	1064
Objective (f in mm)	100	160	163	254
Aperture (mm)	15	15	15	15
Spot Size TEM ₀₀ (μm)	13	21	21	34
Scan Angle (maximum °optical)	$\pm 21^\circ$	$\pm 21^\circ$	$\pm 21^\circ$	$\pm 21^\circ$
Standard Field Size (mm ²)	60 x 60	95 x 95	114 x 114	178 x 178
Maximum Practical Field Size (mm ²) ¹	73 x 73	117 x 117	120 x 120	186 x 186
Working Distance (mm) ²	147	218	200	316
Relative Position Repeatability (μm)	< 1.25	< 2	< 2	< 3.2
Dither (μm)	< 3.2	< 5	< 5	< 7.8
Writing Speed (m/s) ³	≤ 1.25	≤ 2	≤ 2	≤ 3.2
Non-Writing (Jump) Speed (m/s) ⁴	≤ 2.5	≤ 4	≤ 4	≤ 6.4
Dynamic Stability (μm)	< 9.5	< 15	< 15	< 24
Long Term Stability (μm)	< 6.3	< 10	< 10	< 16
Power Capability, CW (W/cm ²)	500	500	500	500
Power Capability, 100 ns pulsed (MW/cm ²)	100	100	100	100
Laser Power Loss, Including Lens ⁵	< 11%	< 11%	< 11%	< 11%
Weight (kg) ⁶	4.2	4.2	4.6	5.2
Operating Temperature (°C)	$25^\circ \pm 10^\circ \text{C}$			

¹ Some beam clipping may occur

² Distance between lens ring mounting surface and working field (see [outline drawing](#))

³ Actual writing speed depends on accuracy and feature sizes

⁴ Jump speeds (jumps when the laser is off) may be much higher than writing (laser-on) speeds

⁵ Rodenstock F-theta transmission spec <10%

⁶ Scan Head weight without lens: 3.8 kg

Specifications are subject to change without notice.

See your GSI Lumonics sales representative for more details.

2.2.2 CO2 lens specifications:

Laser Type	CO ₂	CO ₂	CO ₂	CO ₂
Wavelength λ (nm)	10600	10600	10600	10600
Objective (f in mm)	100	200	200 HP	300
Aperture (mm)	15	15	15	15
Spot Size TEM ₀₀ (μ m)	224	262	265	382
Scan Angle (maximum °optical)	$\pm 21^\circ$	$\pm 21^\circ$	$\pm 21^\circ$	$\pm 21^\circ$
Standard Field Size (mm ²)	55 x 55	110 x 110	140 x 140	165 x 165
Maximum Practical Field Size (mm ²) ¹	70 x 70	140 x 140	140 x 140	210 x 210
Working Distance (mm) ²	102	202	202	300
Relative Position Repeatability (μ m)	< 1.25	< 2.5	< 2.5	< 3.75
Dither (μ m)	< 3.2	< 6.4	< 6.4	< 9.6
Writing Speed (m/s) ³	≤ 1.25	≤ 2.5	≤ 2.5	≤ 3.75
Non-Writing (Jump) Speed (m/s) ⁴	≤ 2.5	≤ 5	≤ 5	≤ 7.5
Dynamic Stability (μ m)	< 9.5	< 19	< 19	< 28.5
Long Term Stability (μ m)	< 6.25	< 13	< 13	< 19
Power Capability, CW (W/cm ²)	500	500	500	500
Power Capability, 100 ns pulsed (MW/cm ²)	400	400	400	400
Laser Power Loss, Including Lens ⁵	< 2.5%	< 2.5%	< 2.5%	< 2.5%
Weight (kg) ⁶	4.1	4.1	4.2	4.1
Operating Temperature (°C)	$25^\circ \pm 10^\circ$ C			

¹ Some beam clipping may occur

² Distance between lens ring mounting surface and working field (see [outline drawing](#))

³ Actual writing speed depends on accuracy and feature sizes

⁴ Jump speeds (jumps when the laser is off) may be much higher than writing (laser-on) speeds

⁵ Rodenstock F-theta transmission spec <10%

⁶ Scan Head weight without lens: 3.8 kg

Specifications are subject to change without notice.

See your GSI Lumonics sales representative for more details.

2.3 Power Supply Requirements

Customers must supply a power supply with the following specifications:

Voltage: $\pm 15V$ +60% -20%
 Current: 2 Amps
 Ripple: $\leq 0.2\%$
 Noise: $\leq 0.5\%$ DC to 30MHz

2.4 Environmental Requirements

Storage Temperature: -10°C to $+60^{\circ}\text{C}$
 Minimum Operating Temperature: $+15^{\circ}\text{C}$
 Maximum Operating Temperature: $+35^{\circ}\text{C}$
 Humidity: Non-condensing

2.5 Mirror Specifications

	YAG	CO ₂	DYAG
Wavelength	1,064 nm	10,600 nm	532 nm
Coating	Dielectric	Dielectric On Metal	Dielectric
Reflection (min.) @ Wavelength (nm)	99.5% @ 1,064 nm	99% @ 10,640 nm	99.5% @ 532 nm
	80.0% @ 633 nm	80% @ 633 nm	80% @ 633 nm
Flatness @ 633 nm	$\lambda/4$	$\lambda/4$	$\lambda/4$
Power Capability, CW (W/cm ²) MAX	500	500	500
Power Capability, 100 ns pulsed (MW/cm ²) MAX	100	100	100
Surface Quality (Scratch/Dig)	40/20	40/20	40/20

3 SYSTEM DESCRIPTION

3.1 Analog Interface

The analog interface HSM15M2 system configuration includes the head itself and optional field flattening lens kit. This configuration requires the user to supply analog voltages to command the galvanometers within the head. A differential input signal of $\pm 5V$ will command a maximum deflection of $\pm 20^\circ$ optical. The user must supply power (power supply specifications provided in section 2.2 [Specifications – All Configurations](#)) and cabling for both 25-pin Analog I/O Connection and 9-pin Power Connection. Pin-outs are provided below. A functional description of each pin is provided on the following page.

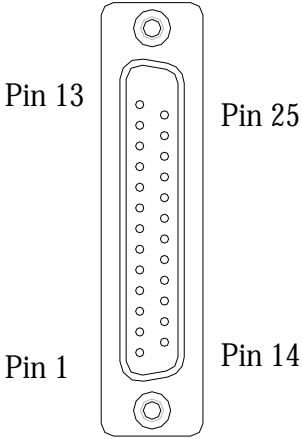
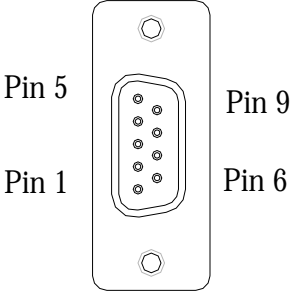
INTERFACE	PIN	ASSIGNMENT
 <p>25-Pin D-sub (Male) Analog I/O Connection</p>	<p>13 25 12 24</p>	<p><u>Signal Connections</u> +X COMMAND -X COMMAND +Y COMMAND -Y COMMAND</p>
	<p>11 23 10 22 9</p>	<p><u>Feedback Connections</u> SIGNAL GROUND TEMP OK SIGNAL GROUND SERVOS OK NOT SIGNAL GROUND</p>
<p>1 - 8 14 - 21</p>	<p><u>Reserved Pins</u> NOT CONNECTED NOT CONNECTED</p>	
INTERFACE	PIN	ASSIGNMENT
 <p>9-Pin D-sub (Male) Power Connection</p>	<p>9</p>	<p>+Vin</p>
	<p>3</p>	<p>GND</p>
<p>6</p>	<p>-Vin</p>	
<p>1, 2, 4, 7 - 9</p>	<p>NOT CONNECTED NOT CONNECTED</p>	

3.1.1 Analog Pin-Out Description

Each control signal interface allows access to both input and output signals associated with the operation of the XY scanning mirrors. The interface includes the X and Y command inputs and status feedback. By convention, the X mirror refers to the mirror that the beam strikes first inside the scan head. The X-mirror is wider than tall and the Y-mirror is taller than wide.

Command Signal Input

The command input to the servo is a true differential input of $\pm 5V$. The input impedance looking into the $^+$ command input pins while having the $^-$ command grounded is $20k\Omega$. The input impedance looking into the $^-$ command input pins while having the $^+$ command grounded is $10k\Omega$.

Warning! Exceeding the $\pm 5V$ limit may cause series damage to the galvo. The HSM servo does not include over-position circuitry. At an input higher than $\pm 5V$ the mirrors may collide. Be sure to include over-voltage circuitry on the command signal input to ensure the voltage does not exceed $\pm 5V$.

The HSM servo incorporates over-error protection circuitry. If the error of either axis exceeds 2% of field (0.2V) then the output stage becomes weakened preventing high, potentially damaging, levels of current flowing through the galvanometers.

Temp OK

Temp OK is an active high output indicating the X and Y scanners have reached their temperature set point. If either scanner is not at the temperature set point, then the output turns low. This is an open drain output, internally pulled-up through a $10k\Omega$ resistor and capable of sinking $500\mu A$.

Servos OK Not

Servos OK Not monitors the power, X-axis position error, and Y-axis position error. If either of the position errors is greater than 2% of field (0.2V) or if the power level drops below 12V, then the *servos_ok_not* turns high. The *servos_ok_not* is an open collector output internally pulled up to 5V through a $4.7k\Omega$ resistor.

3.2 Digital Interface

The Digital Interface HSM15M2 configuration has the same physical layout as the Analog configuration. Below is a diagram displaying how a typical Digital Interface HSM15M2 system interconnects to control electronics. The female 25-pin connection on HSM15M2 corresponds to the pin-outs of the HC/3 card that resides in a PC. The Digital Interface Cable connects the HC/3 to the HSM15M2 head. [Pin-outs](#) for both signal and power connections are provided on following page. The communication between the HC/3 card and HSM15M2 scan head is the GSI Lumonics developed, industry standard GSI Protocol, as called XY2-100. A functional description of the pins can be found in the corresponding HC/3 Manual. The HC/3 has additional I/O to control a laser as well as trigger and read-in external events.

GSI Lumonics offers two software options for PC control of Digital Interface heads. PC-MARK MT is a DOS based software allowing vector commands to control a scan head. Also available is a Graphical User Interface called Job Editor that links with PC-MARK MT allowing graphic image on-screen to translate to an image produced on the target plane by the scan head. WinMCL Plus is a Microsoft Windows NT[®] family based software (including 2000 and XP) providing driver libraries that can be developed by the user. Refer to corresponding PC MARK MT or WinMCL Plus software manual for more information.

A Typical Digital Interface HSM15M2 system includes:

- ◆ HSM15M2 Scan Head – Digital Interface and optional Field Flattening Lens
- ◆ HC/3
- ◆ Digital Interface Cable (available as an option in 3m and 10m lengths)
- ◆ Software package WinMCL Plus or PC-MARK MT with optional Job Editor front-end

The user must supply power (power supply specifications provided in section 2.2 [Specifications – All Configurations](#)), as well as cabling for 9-pin Power Connection and for Laser Control.

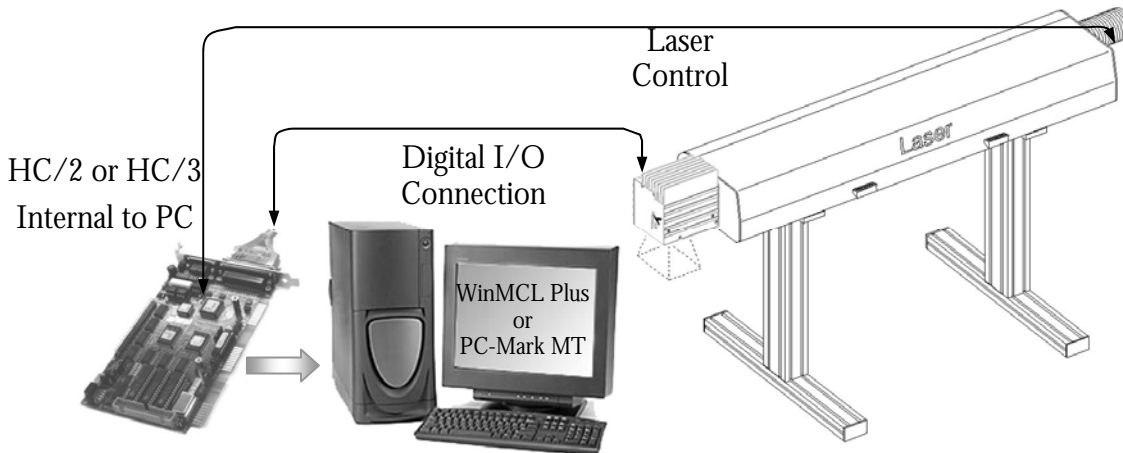
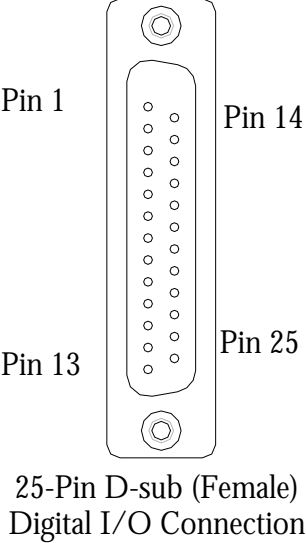
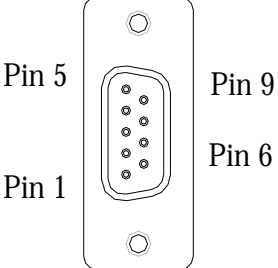

Figure 2.2: Descriptive diagram of a typical digital interface system.

3.2.1 Digital Interface – Pin-Out

INTERFACE	PIN	ASSIGNMENT
 <p>25-Pin D-sub (Female) Digital I/O Connection</p>	<p>1 14 2 15 3 16 4 17 5 18 6 19 11 23 24</p> <p>7 – 10 12 – 13 20 – 22 25</p>	<p><u>HC/3 Connections</u></p> <p>SENDCK - SENDCK + SYNC - SYNC + CHANNEL X - CHANNEL X + CHANNEL Y - CHANNEL Y + RESERVED FOR Z AXIS RESERVED FOR Z AXIS STATUS - STATUS + GROUND GROUND GROUND</p> <p><u>Reserved Pins</u></p> <p>NOT CONNECTED NOT CONNECTED NOT CONNECTED NOT CONNECTED</p>
INTERFACE	PIN	ASSIGNMENT
 <p>9-Pin D-sub (Male) Power Connection</p>	<p>9 3 6</p> <p>1, 2, 4, 7 - 9</p>	<p>+Vin GND -Vin</p> <p>NOT CONNECTED NOT CONNECTED</p>

4 INSTALLATION

GSI Lumonics recommends that you fully enclose and interlock the zone of hazard for your application to prevent possible opening while the laser is energized. If laser radiation exceeding Class 1 levels may exit the enclosure, you must have available suitable protection for your eyes.

4.1 Mounting HSM15M2 Scan Head

The scan head has two holes to receive dowel pins for head alignment in addition to two M6 (metric) threaded holes for mounting. GSI Lumonics recommends creating a mounting flange that will match the mounting holes on the beam input side of the assembly, shown below in Figure 3.1. Use the outline drawings in [Appendix B: Technical Outline Drawings](#) to determine the dimensions for the manufacture of a mounting flange.

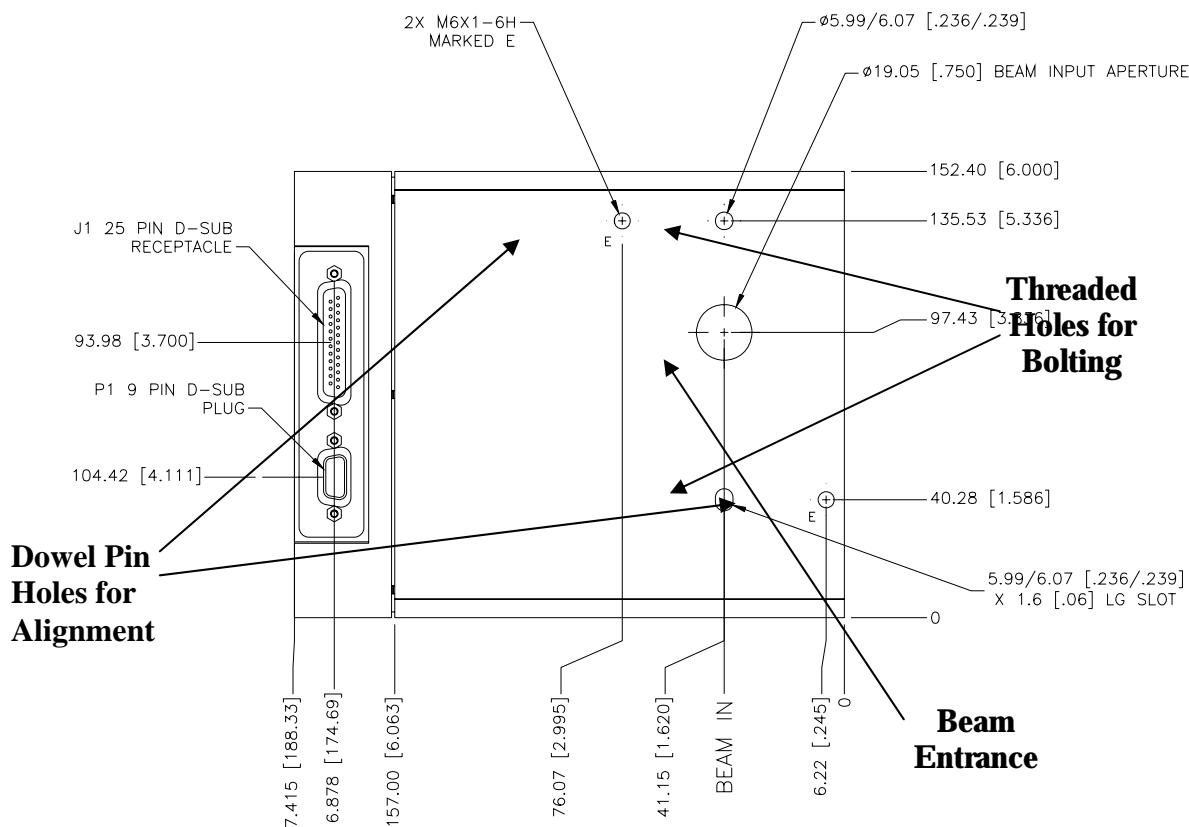

Figure 3.1: The mounting holes are located on the Beam Input side of the HSM15M2 assembly. For complete dimensions see [APPENDIX B: Outline Drawings](#).

4.2 Interconnections

The following figure depicts the connection of the HSM15M2 Scan Head and the HC/3 card to the various other Customer-supplied parts of the system.

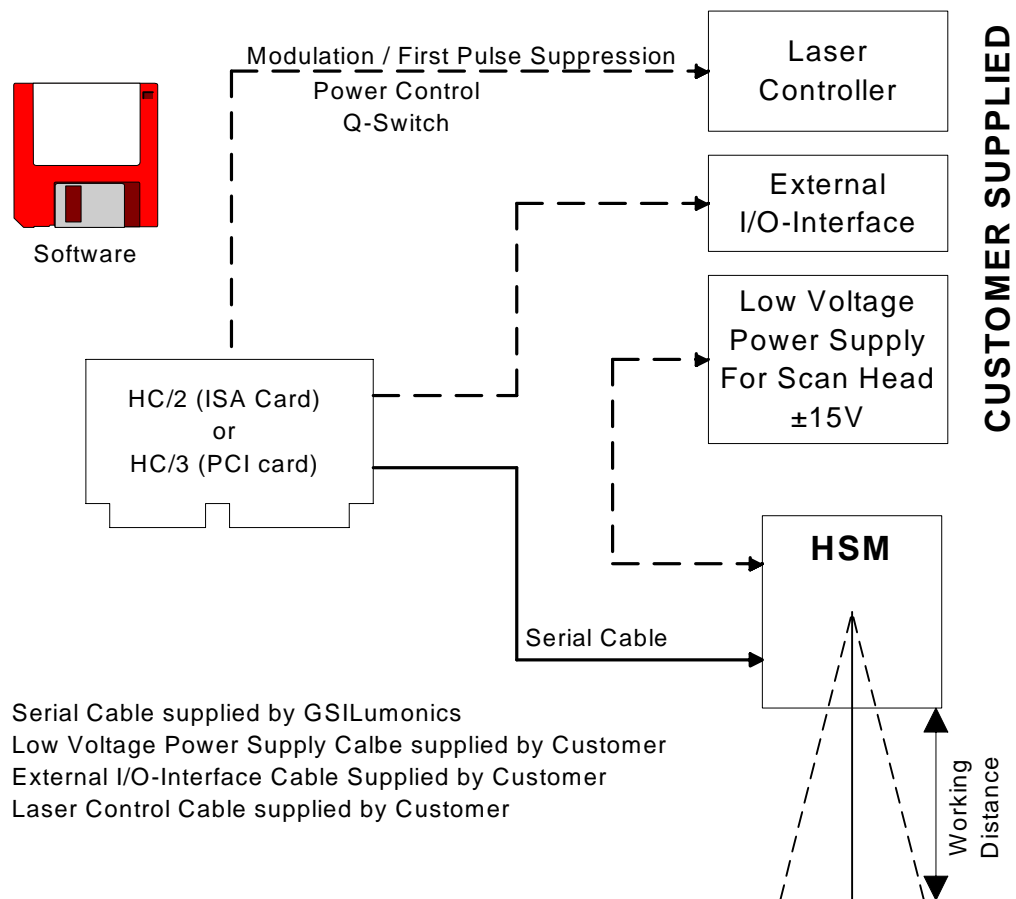

Figure 3.2: Interconnection diagram of the digital interface HSM15M2 and various associated components.

5 SAFETY AND WARNINGS

The United States Food and Drug Administration, through the Center for Devices and Radiological Health (CDRH), has promulgated regulations (21 CFR parts 1000 and 1040) controlling the safety of lasers and laser products for sale or manufacture in the United States.

This section is a guide to the specific areas of this product where laser safety should be addressed. GSI Lumonics Scan Heads are designed to provide maximum flexibility and ease of use. Such a design inherently requires the user to assure the overall safety of the configuration in use.

Note: Prior to operating any configuration of the GSI Lumonics Scan Heads, you must make a thorough analysis of system safety. Key information for this purpose is contained in this manual. You should become familiar with all this information before proceeding.

A full description of laser hazard analysis is beyond the scope of this manual. A technical survey of laser safety requirements can be found in **ANSI Z136.1, "American National Standard For the Safe Use of Lasers"**. This is available from:

*American National Standards Institute, Inc.
1430 Broadway
New York, New York 10018
www.ansi.org*

Among the many other sources of laser safety information, the following institution offers several excellent publications:

*The Laser Institute of America
5151 Monroe Street, Suite 118W
Toledo, Ohio 43623
www.laserinstitute.org*

Your Laser Safety Officer or a competent specialist in this field should make final analysis of all safety features. The first consideration in a safety analysis is the laser mated to the GSI Lumonics Scan Heads. The Laser Class label on the device indicates the approximate hazard level of the laser. Refer to **ANSI Z136.1** for definitions of laser classes and labeling information. Note that, besides radiation, lasers may present other hazards, e.g. electric shock or creation of poisonous fumes.

Note: The GSI Lumonics Scan Heads provide you with the ability to aim the laser beam over a roughly pyramidal volume. The divergence of the focused beam beyond the focal point, which is a function of the lenses selected and their position, can cause radiation to exit the pyramid. When analyzing safety, you must consider all regions within this aiming pyramid, the divergent beam, and the effects of all focal possibilities in the zone of hazard. Reflections must also be considered.

5.1 Laser Shutter Installation

The laser attenuator (shutter) is not included with the Scan Head. Because each laser is unique, it is the user's responsibility to insure that such a device is incorporated as required.

CFR 1040.10 [f] [6] states:

“A beam attenuator is required on Class II, IIIa, IIIb and IV laser systems. The beam attenuator is a mechanical or electrical device such as a shutter or attenuator that blocks emission. The beam attenuator blocks bodily access to laser radiation above Class I limits without the need to turn off the laser. The beam attenuator must be available for use at all times during operation. Power switches and key controls do not satisfy the attenuator requirement.”

Refer to CFR 1040.10 for more information.

The beam shutter should be installed between the laser head and the Scan Head. The following figure shows the recommended location of the shutter.

We strongly recommend that you specify a laser with a vendor-supplied shutter mechanism. If this is not possible, consult the laser vendor to design a proper safety shutter.

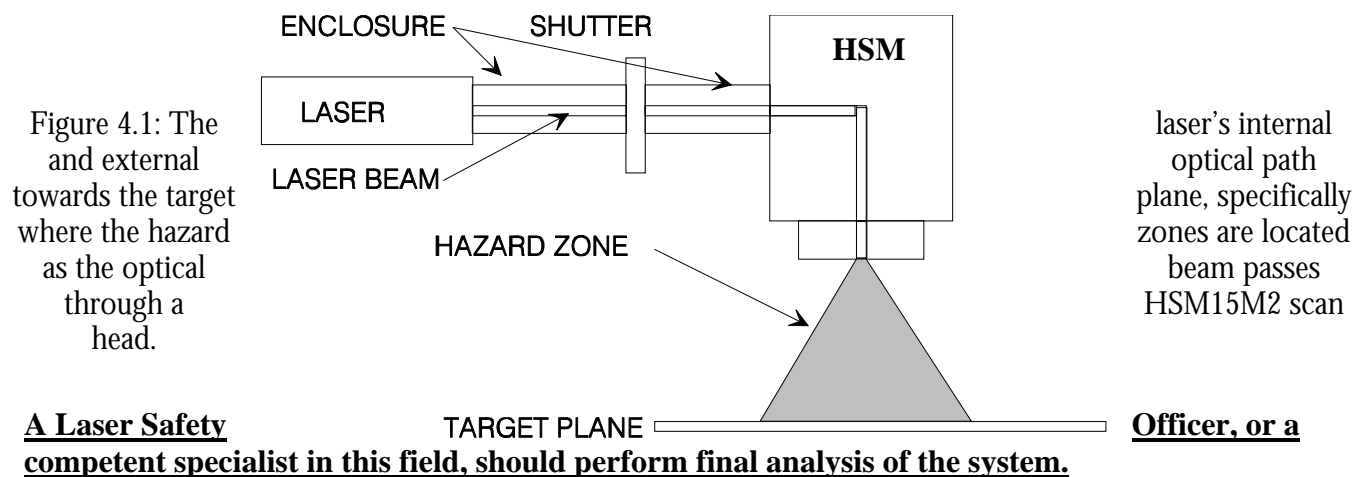

5.2 Installation Safety Requirements

For the digital interface of the HSM15M2 Scan Head, the head should be interconnected for software shut down of the laser. This will ensure safety during operation, error or recovery of the Scan Head.

In all cases, we recommend that you fully enclose and interlock the zone of hazard for your application to prevent possible beam deflections while the laser is energized. Refer to ANSI Z136.1 to determine what protective equipment is required.

At no time should you stare into the beam, place any parts of your body in the beam path, or expose yourself to reflections of powerful beams. You should use only a Class 1 HeNe Laser for alignment. If this is not possible, you should use the available laser's lowest power. Using optical instruments with this product increases eye hazard.

Additional Safety requirements may be applicable during initial alignment of the optical system. Refer to [Section 4 Safety and Warnings](#).

6 HANDLING / MAINTENANCE

GSI Lumonics XY Scan Heads do not contain any user serviceable or user maintainable parts. However, you should visually inspect all optical surfaces each time lenses and alignment mirrors are handled.

All contamination on optical surfaces must be removed prior to operation or serious damage and/or hazard may result. The Scan Head must be protected from airborne contaminants. Dust attaching through impact or vapors condensing on the optical surfaces reduces the mirror's reflectivity. Furthermore, avoid scanner exposure to dust, condensation or cleaning fluids.

- ◆ Make sure that the laser is off before performing any inspections! Wear finger cots or cotton gloves when handling optics.
- ◆ You must be extremely careful not to allow contaminants from entering the galvanometer itself. Serious scanner damage may result.

If you feel that cleaning or service is necessary, contact the [customer service](#) group at GSI Lumonics for information regarding service.

6.1 Mirror Cleaning

Although the user can replace the mirrors, we **do not recommend** you do so. Furthermore, GSI Lumonics **does not recommend cleaning front surface mirrors**. Mirrors damaged by cleaning are **not included under the [warranty](#)**. The surface of these mirrors damage easily. Prevention of hard dust particles from being entrained in the process and causing scratches is difficult. In many cases, small defects in the mirror's surface may be less harmful than the surface damage resulting from continued cleaning. Cleaning requires special equipment typically not available to typical users.

There are times, however, when cleaning the mirror becomes a necessity, e.g. stains such as fingerprints must be removed immediately to prevent permanent etching of the reflective surface. The information below includes general recommendations for those special occasions when mirrors must be cleaned.

Remove lint from mirrors with a jet of low pressure clean air or nitrogen. Blowing on front surface of mirrors with mouth deposits moisture that may stain the finish.

A thin overcoating of silicon monoxide protects most mirrors from oxidation. Like many optical coatings, it is easily damaged when attempts are made to clean the mirror surface with a dry tissue.

The safest method of cleaning is to place a piece of lens tissue wet with reagent grade (highly pure) alcohol. Lay the wet tissue over the surface of the mirror, gently agitate it, then slide the tissue off. If an uneven film remains when dry, repeat the process, but use a jet of low pressure clean air or nitrogen to quickly spread remaining liquid. This should remove the problem blemishes.

- ◆ Note that the mirror is not rubbed.
- ◆ Do not let solvent enter the bonded zone of the mirror.

Do not let solvent enter the scanner bearings. When wetting the mirror's surface, hold the Scan Head at an angle so that the liquid does not wet the scanner. If any solvent is found in the bearings of the scanner, the warranty is voided

7 TROUBLESHOOTING

If you encounter problems with a HSM15M2 Scan Head, check the following matrix. If you cannot solve the problem, contact [GSI Lumonics technical support](#) for further assistance.

PROBLEM	PROBABLE CAUSE	POSSIBLE SOLUTION
1. Decrease in marking quality.	1. Dirty or Damage lens or protection glass.	1. Clean glass per instructions in Maintenance Section. 2. Replace protection glass
	2. Drop in output power.	1. Check laser power.
2. Laser will not mark when ordered by computer.	1. Laser modulation malfunction.	1. Check connections between laser controller and laser.
	2. No power to galvanometers.	1. Check power connections to scanning head.

8 GLOSSARY

Flat Field Lens: A wavelength specific lens focuses the laser to a small spot and maintains this spot size over the entire target field.

Galvanometer: Extremely linear limited rotation magnetic torque motor. The galvanometer (galvo) rotates a mirror to direct the laser beam.

DAR: Digital to Analog Receiver converts digital sequences from the HC/2 or HC/3 card and converts them to analog signals for commanding each galvanometer within a scan head.

HC/3: A PCI card internal to a PC providing the hardware link between software commands and a scan head. Optoisolation and I/O for laser control and parts handling are additional features. The HC/3 is fully compatible with PC-MARK MT (multitasking) software and WinMCL.

HPGL: HP® Graphics Language, a graphics format which PC-MARK MT or WinMCL can translate into vector data for scanning.

HSM: (High Speed Module) Complete beam position package consisting of a XY Industrial Scan Head, high bandwidth servo electronics, and digital or analog interfaces.

PC-MARK MT: A front-end macro command language. PC-MARK MT accepts application commands to place text and graphics in the marking field and translates them into the appropriate lists of vectors. Users may also write their own PC-MARK MT programs in any one of many popular software languages. The sub-language of PC-MARK, MMCL is utilized as the link to the HC/2 card.

JOB EDITOR: A menu-driven application program of PC-MARK MT that provides a graphics user interface and file management. It allows the user to manipulate HPGL based graphics with an accurate real preview of one's job.

WinMCL Plus: Developer level, Windows© NT based macro command language. Programs can be written in a Visual C++ environment to invoke positioning. The language also supports some laser control features. It interfaces with both the HC/2 and HC/3 card.

GMAX, HC/2, HC/3, HCI, PC-MARK MT, and WinMCL Plus are trademarks of GSI Lumonics.
Microsoft, MS-DOS and Windows are registered trademarks of Microsoft Corporation. HP is a registered trademark of Hewlett-Packard Company.

9 APPENDIX A: ADDITIONAL RESOURCES

Digital Interface:

PC-MARK MT™ / PC-MARK Command Reference: GSIL P/N: 176-25008

PC-MARK MT Programmer's Manual: GSIL P/N: 176-25015

HC/3™ and HC/3 M-S [HelperCard III] PC Hardware Controller Reference Manual:
GSIL P/N: 7OM-034

WinMCL Plus Technical Reference: GSIL P/N: 7OM-1095

10 APPENDIX B: OUTLINE DRAWINGS

This appendix includes an outline drawing of the HSM15M2 Scan Head, *GSI Lumonics*' drawing number 7CD-76315. Note the digital interface head is shown. The analog interface only varies in the signal connector, which is a male connector rather than a female connector shown for the digital interface.

10.1 HSM15M2 Analog or Digital Interface Scan Head

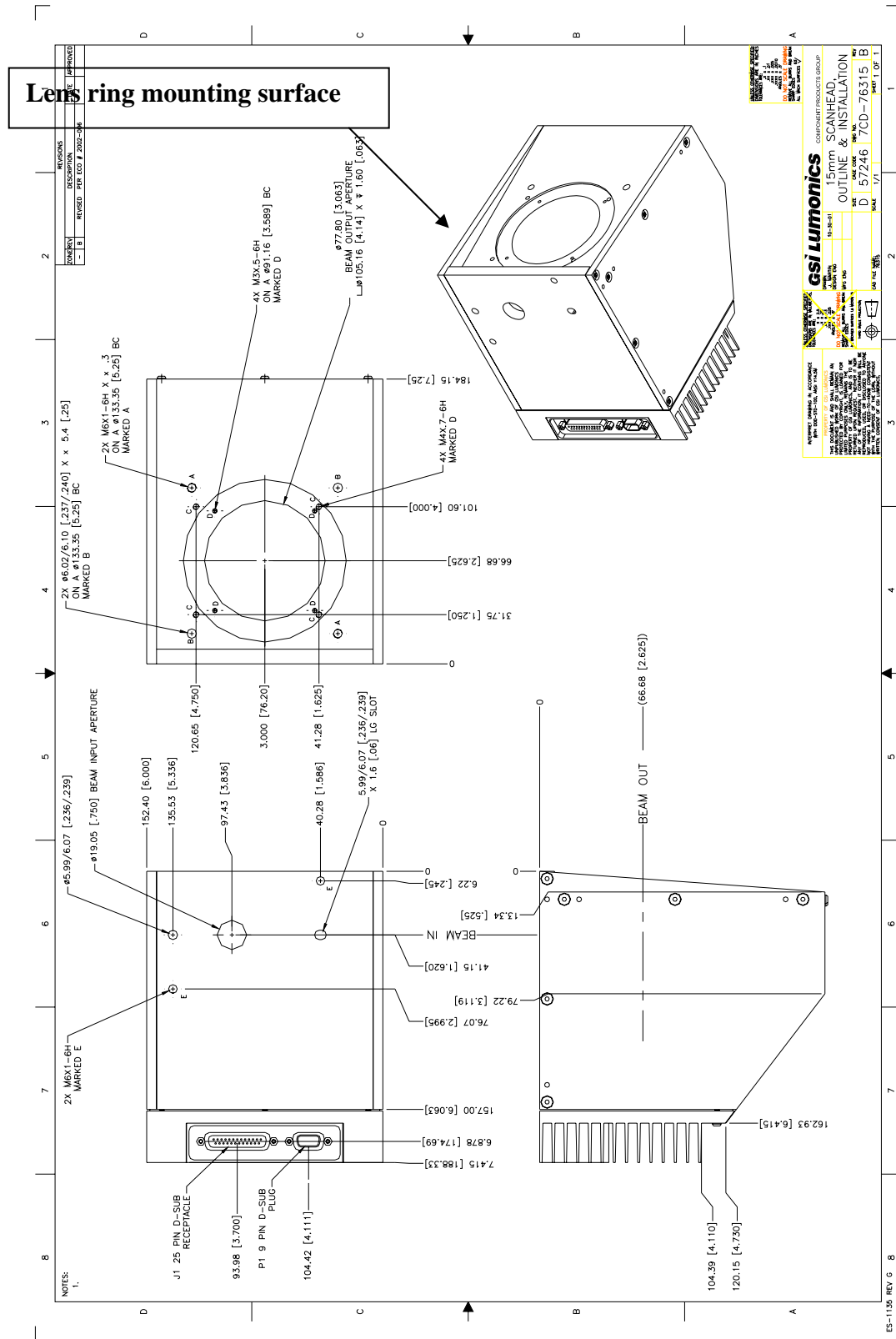

END OF DOCUMENT